

Clippard

PROPORTIONAL VALVES



Proportional Valves

EVP Series Proportional Valve

Precision-built utilizing Clippard's renowned Spider technology with the additional capability for proportional control. The EVP series valve provides air or gas flow control and varies the output flow based on the current input to the solenoid. Controllability and overall value are the main features of the EVP series. The consistent gain of this valve provides a high degree of control for many applications.

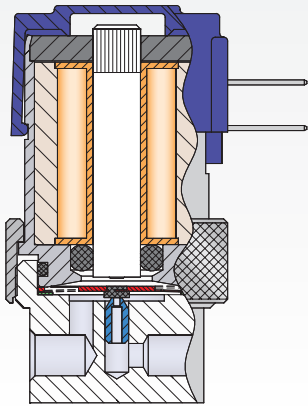

p. 4

3 voltage coils

≤10% hysteresis

~±10% of given flow target

Fast response

Long life

DVP Series Proportional Valve

Like the EVP series, the DVP also provides proportional control utilizing Clippard's renowned Spider technology.

In addition, the DVP series offers an extremely high cycle life, fast response, linear flow gain, low power consumption, and flows over 60 l/min. The DVP provides air or gas flow control and varies the output flow based on the current input to the solenoid.

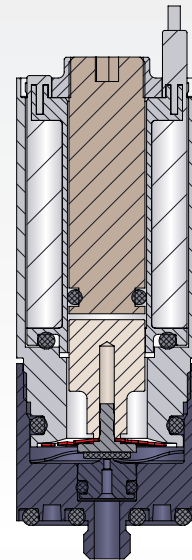

p. 8

Higher flow (over 60 l/min)

Fast response

Long life

SCPV Series Stepper Needle Valve

Utilizing the industry's most robust and powerful linear actuator, Clippard's high flow SCPV series stepper-controlled proportional valve is ideal for critical medical, analytical, and industrial automation applications. The SCPV is an excellent choice where high resolution, high flow, low hysteresis, and variable control of inert gases is required. In addition, the simple design is customizable to allow for unique flow curves more specific to your application needs.

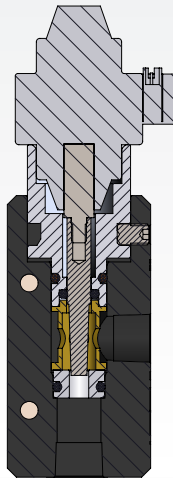

p. 14

High accuracy stepper-driven needle valve

Fully customizable design

Very low hysteresis

"Set it and forget it" control

0.001" (0.03 mm) step resolution

Eclipse Proportional Isolation Valve

The patented, stepper-controlled Eclipse proportional isolation valve leads the industry in performance and durability. This valve is ideal in critical applications for liquid and gas delivery, medical, analytical and industrial automation requiring ultra fine resolution and excellent repeatability. In addition, the unique design allows for custom flow profiles.

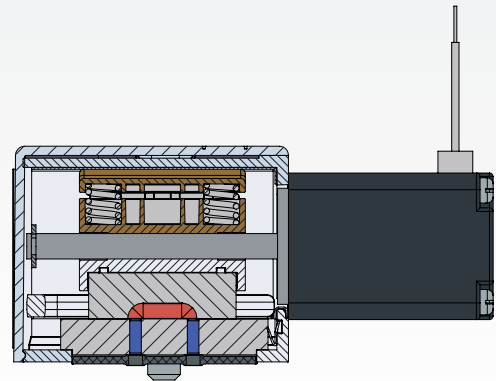

p. 16

Ceramic sliding seal

Liquid capable

Zero dead volume (fully flushable)

0.0009 in³ (0.0154 cm³)

Unique, patented design

Ultra-fine resolution

EVP PROPORTIONAL VALVES



The EVP series proportional control valves combine the features of the existing EV series valve—long life, low power, and Clippard’s reputation for high quality components—with the additional capability for proportional control. The EVP series valve provides air or gas flow control and varies the output flow based on the current input to the solenoid.

Controllability and overall value are the main features of the EVP proportional valve series. The consistent gain of this valve provides a high degree of control for many applications. The valve may be controlled using DC current, open or closed-loop control, and even PWM (pulse width modulation) to cover a broad range of applications.

Coil Resistance	13.5, 54, 218 Ω @ 72°F (22°C)
Connection	Square pin, terminal spades, or 18" (45.7 cm) wire leads
Current	0 to 0.370 A, 0 to 0.185 A, 0 to 0.092 A
Driver	EVPD (optional)
Filtration	40 micron filter (recommended)
Flow Range	Up to 22 l/min
Function	2-way normally-closed proportional
Material, Body	Nickel plated brass
Material, Seals	Nitrile, FKM, or EPDM
Material, Seat	Stainless steel
Material, Wetted	ENP brass, ENP steel, stainless steel
Max. Flow	$\pm 10\%$ of target flow
Max. Hysteresis	$\leq 10\%$ of full current
Max. psig	100 psig (7 bar)
Medium	Clean, dry air or inert gases
Mount	In-line threaded ports or manifold
Number of Ports	2
Operating Pressure	Vac. to 100 psig (0.3 to 7 bar)
Operating Temp. Range	32 to 120°F (0 to 48°C)
Orifice	0.009", 0.013", 0.025", 0.040", 0.060" (0.23, 0.33, 0.64, 1.00, 1.52 mm)
Port, Inlet	#10-32 female or manifold stud
Port, Outlet	#10-32 female or manifold outlet hole
Power Requirement	1.9 watts @ 72°F (22°C); 2.3 watts max.
Voltage	5, 10, or 20 VDC nominal
Wattage	1.9 watts @ 72°F (22°C), 2.3 watts max.
More Details	clippard.com/link/evp-series

Typical Performance

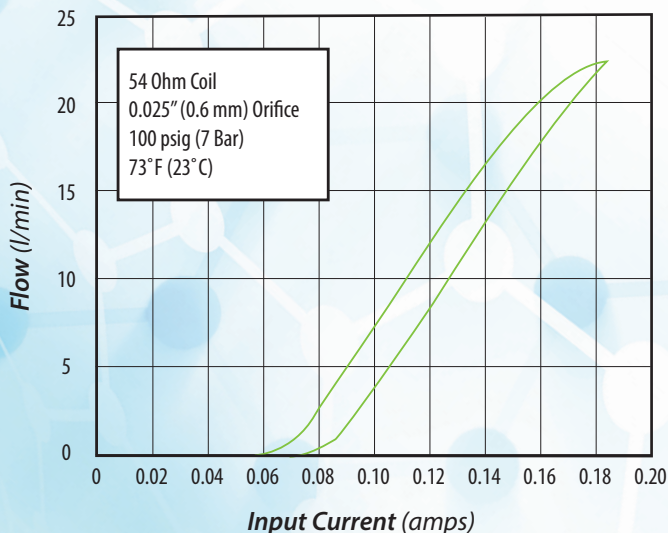

The above flow curve is a typical calibration record for the EVP. All proportional valves have a stored calibration data sheet readily available upon request.

Inline Mount

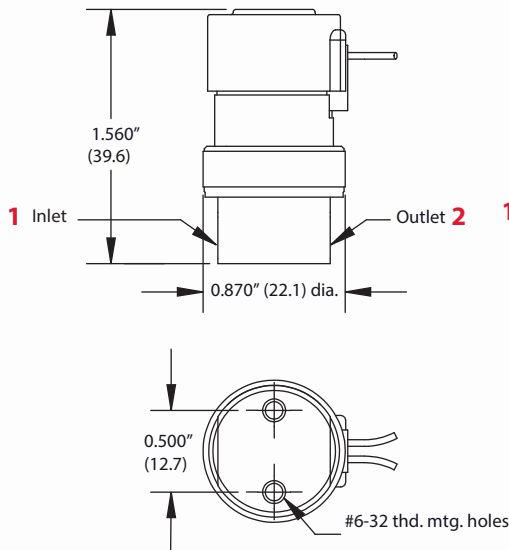

Manifold Mount

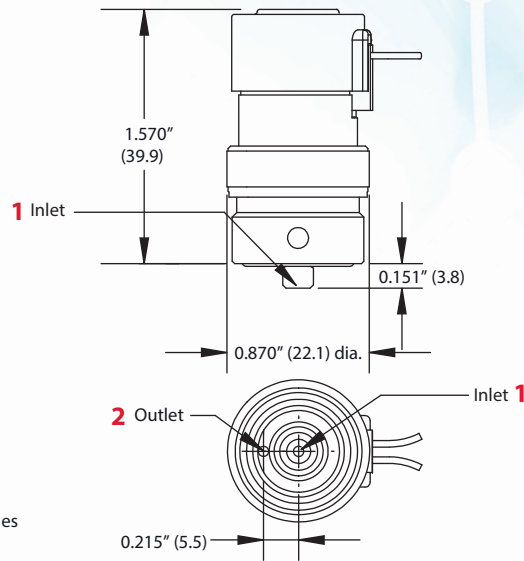

Manifolds

15490-1	Pilot Manifold #10-32 Inlet, 1/8" NPT Outlet
15490-2	Single Supply 1/8" NPT Inlet, #10-32 Outlet
15490-3	Dual Supply 1/8" NPT Inlet, #10-32 Outlet
15491-1	Side-Ported #10-32 Inlet, 1/8" NPT Outlet
15491-2	Side-Ported 1/8" NPT (R1/8) Inlet, #10-32 Outlet
15490-5	Single-Station 1/8" NPT Inlet, 1/8" NPT Outlet
15481-2	Single-Sided 2-Station
15481-4	Single-Sided 4-Station
15481-6	Single-Sided 6-Station
15482-8	Double-Sided 8-Station
15482-12	Double-Sided 12-Station

Dimensions shown are in inches (millimeters listed in parentheses).
Visit clippard.com for more detailed 2D and 3D drawings.

- Flow proportional to input current
- Fast response and long life

ORDERING INFORMATION

E - **P** - **□** - **□** - **□** - **□** - **□** - **□**

Electrical Connection

- C Connector
- T Terminal Spades
- V Wire Leads

Mounting

- (blank) Base Mount
- M Manifold Mount

Voltage

- 05 0 to 5 VDC
- 10 0 to 10 VDC
- 20 0 to 20 VDC

Seal

- (blank) Nitrile
- E EPDM¹
- V FKM¹

Orifice*

- 09 0.009" (0.23) dia., 2.7 l/min ±10%, max. 100 psig (7 bar)
- 13 0.013" (0.33) dia., 6.7 l/min ±10%, max. 100 psig (7 bar)
- 25 0.025" (0.64) dia., 22.0 l/min ±10%, max. 100 psig (7 bar)
- 40 0.040" (1.02) dia., 18.7 l/min ±10%, max. 50 psig (3.4 bar)
- 60 0.060" (1.52) dia., 14.0 l/min ±10%, max. 25 psig (1.7 bar)

Maximum Pressure (5 psig to 100 psig)

- 00 In increments of 5, from 05 to 95
- A0 100 psig

¹Min. order quantity required for EPDM or FKM seals.

Please Note: Not all possible configurations are valid.
Consult the online configurator at clippard.com.

Example Part Number:
EC-P-05-0925

For more info, scan the
QR code or visit
clippard.com/link/evp-series



A Close-Up of the EVP Series

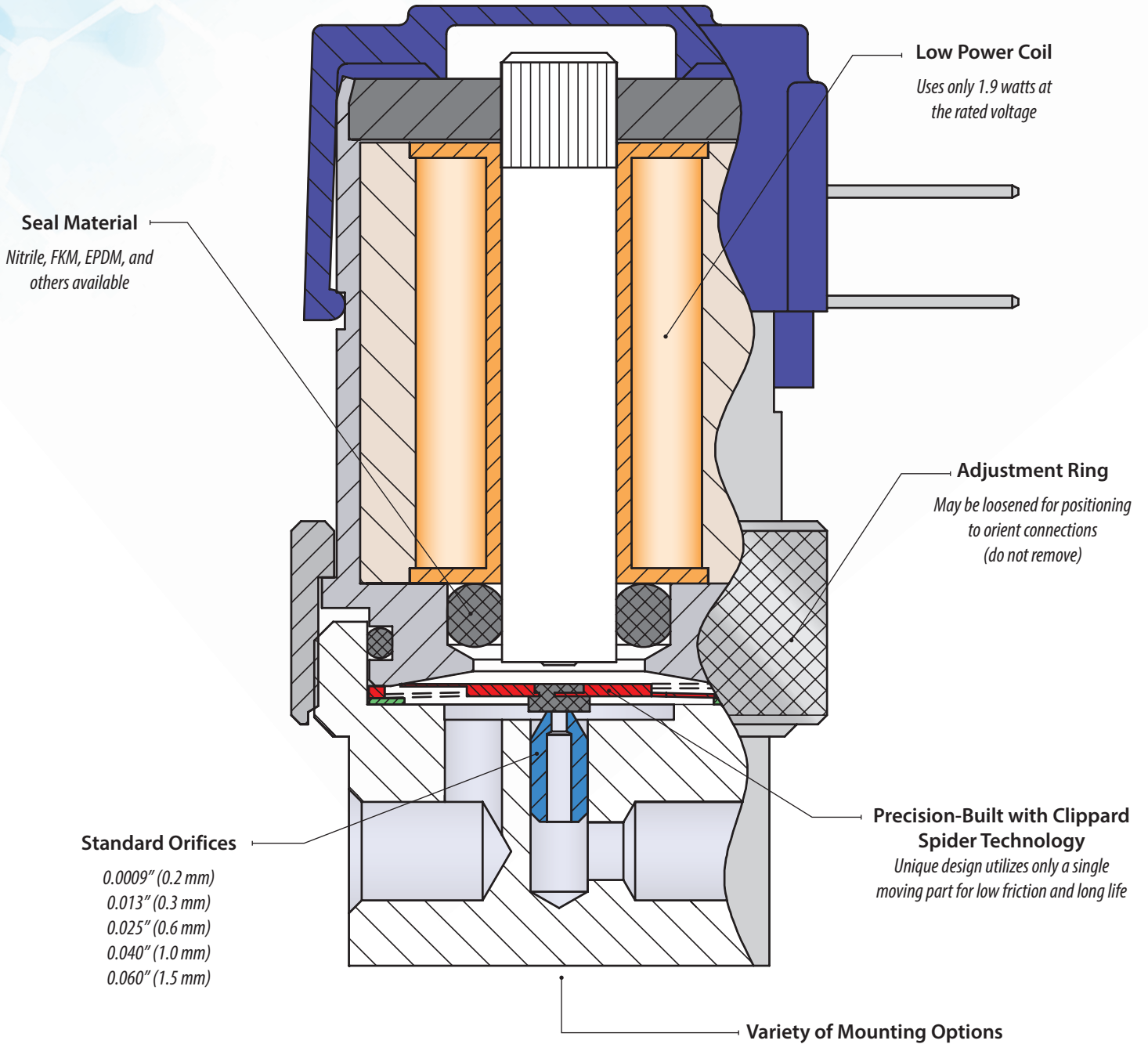

How to Select Your EVP Proportional Valve

When choosing your valve, there are many variables to consider. To select the best valve for your application, focus on:

- 1 Control Signal
- 2 Valve Orifice
- 3 Operating Pressure

Please Note: It is important to specify and use a calibrated valve that matches your application. Be sure to use a valve set to your operating pressure. Otherwise, the required power for opening the valve will be high and the resolution to set your flow proportional will be poor.

1 CONTROL SIGNAL

Voltage Range	Input Current Range	Coil Resistance	Max. Voltage Required
0 to 5 VDC @ 72°F (22°C)	0 to 0.370A	13.5 ohms @ 72°F (22°C)	6.2 VDC
0 to 10 VDC @ 72°F (22°C)	0 to 0.185A	54 ohms @ 72°F (22°C)	12.4 VDC
0 to 20 VDC @ 72°F (22°C)	0 to 0.092A	218 ohms @ 72°F (22°C)	24.8 VDC

Note: Do not exceed input current range

2 VALVE ORIFICE (Maximum Working Pressure)

Orifice Diameter	Rated Pressure	Flow at Max. Current (±10%)
0.009" (0.23 mm)	100 psig (7 bar)	2.7 l/min @ 100 psig (7 bar)
0.013" (0.33 mm)	100 psig (7 bar)	6.7 l/min @ 100 psig (7 bar)
0.025" (0.64 mm)	100 psig (7 bar)	22.0 l/min @ 100 psig (7 bar)
0.040" (1.02 mm)	50 psig (3.4 bar)	18.7 l/min @ 50 psig (3.4 bar)
0.060" (1.52 mm)	25 psig (1.7 bar)	14.0 l/min @ 25 psig (1.7 bar)

Note: Maximum flow is measured at maximum pressure

3 OPERATING PRESSURE - Maximum Flow vs. Operating Pressure

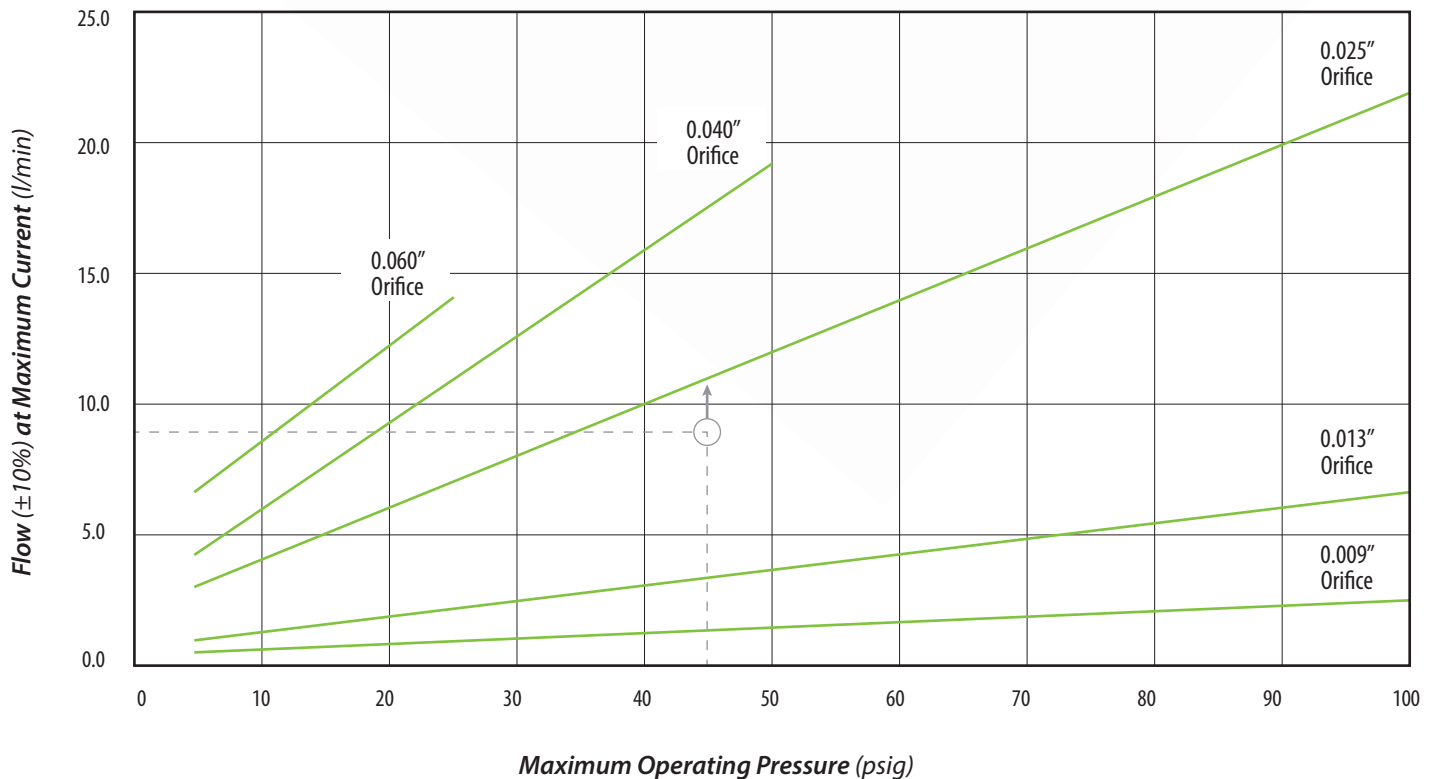

To determine the correct orifice required, locate the colored line immediately above the flow/pressure intersection.
 Example: 9 slpm required at 45 psig inlet. This example leads to a ~2545" valve (0.025" nozzle, 45 psig).

DVP PROPORTIONAL VALVES



Clippard's DVP series proportional solenoid valves are precision-built 2-way control valves. With its solid, compact design, long life, and exceptionally high flow rates, these valves are suitable for a wide variety of applications across many different industries.

The DVP valve provides air or gas flow control and varies the output flow based on the current input to the solenoid. The valve's consistent gain provides a high degree of control. It may be controlled using DC current, open or closed-loop control, and even pulse width modulation (PWM) to cover a large range of applications.

Coil Resistance	52.6, 210.5 Ω @ 72°F (22°C)
Connection	Terminal spades or 18" (45.7 cm) wire leads
Current	0 to 0.190 A, 0 to 0.095 A
Cycle Life	1,000,000,000+
Driver	EVDP (optional)
Filtration	40 micron filter (recommended)
Function	2-way normally-closed proportional
Material, Body	Stainless steel
Material, Seals	FKM, nitrile, EPDM, or silicone
Material, Seat	Stainless steel
Material, Wetted	304 stainless steel, PPS
Max. Flow	+10%, -0%
Medium	Air or compatible gases
Mount	Manifold, #10-32 male stud
Number of Ports	2
Operating Pressure	Vac. to 100 psig (7 bar)
Operating Temp. Range	32 to 120°F (0 to 49°C)
Port, Inlet	Manifold stud
Port, Outlet	Manifold outlet hole
Voltage	10 or 20 VDC nominal
Wattage	1.9 watts @ 72°F (22°C), 2.5 watts max.
More Details	clippard.com/link/dvp-series

Typical Performance

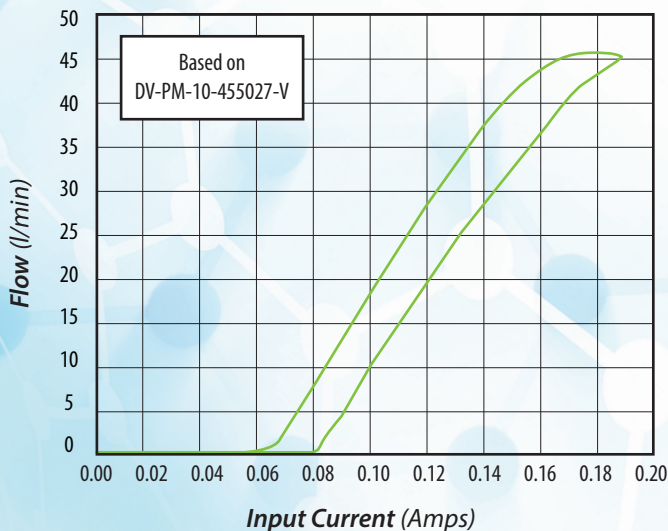

The above flow curve is a typical calibration record for the DVP. All proportional valves have a stored calibration data sheet readily available upon request.

Spade Terminals

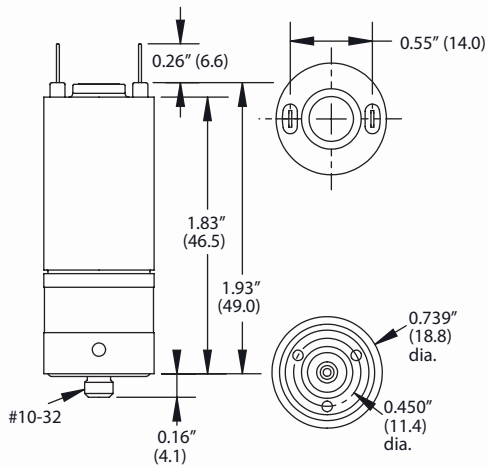

Wire Leads

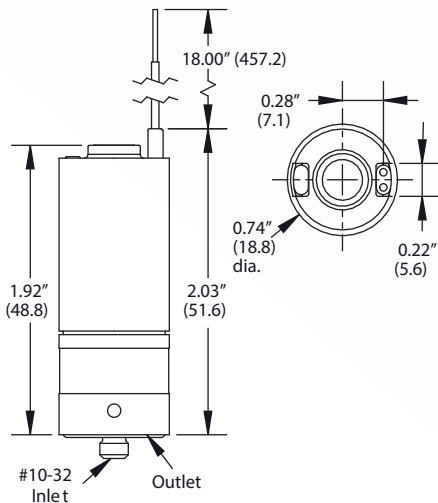

Manifolds

15490-5	Single-Station, ENP Brass
15781-2	2-Station, Black Anodized Aluminum, 1/8" NPT
15781-4	4-Station, Black Anodized Aluminum, 1/8" NPT
15481-6	6-Station, Black Anodized Aluminum, 1/8" NPT

Dimensions shown are in inches (millimeters listed in parentheses).

Visit clippard.com for more detailed 2D and 3D drawings.



- Extremely low hysteresis
- Low heat rise / low power
- Flow proportional to input current
- Robust stainless steel spring, base, and housing
- Industry standard for leak-free operation
- Over 1,000,000,000 cycles

ORDERING INFORMATION

D - **P** **M** - - - - -

Electrical Connection

- T Spade Terminals
- V Wire Leads (Axial)

Voltage

10 10 VDC
20 20 VDC

Flow

In increments of 1, from 010 to 678
(1.0 l/min to 67.8 l/min)

Example: 300 (300 l/min)

Operating Pressure

In increments of 1, from 005 to 100
5 psig (0.4 Bar) to 100 psig (6.9 Bar)

Example: 040 (40 psig, 2.8 bar)

Seals

- V FKM (standard)
- (blank) Nitrile
- E EPDM¹
- S Silicone¹

¹Min. order quantity required for EPDM or silicone seals

Example Part Number:

DT-PM-10-300-040-V

For more info, scan the QR code or visit

clippard.com/link/dvp-series



A Close-Up of the DVP Series

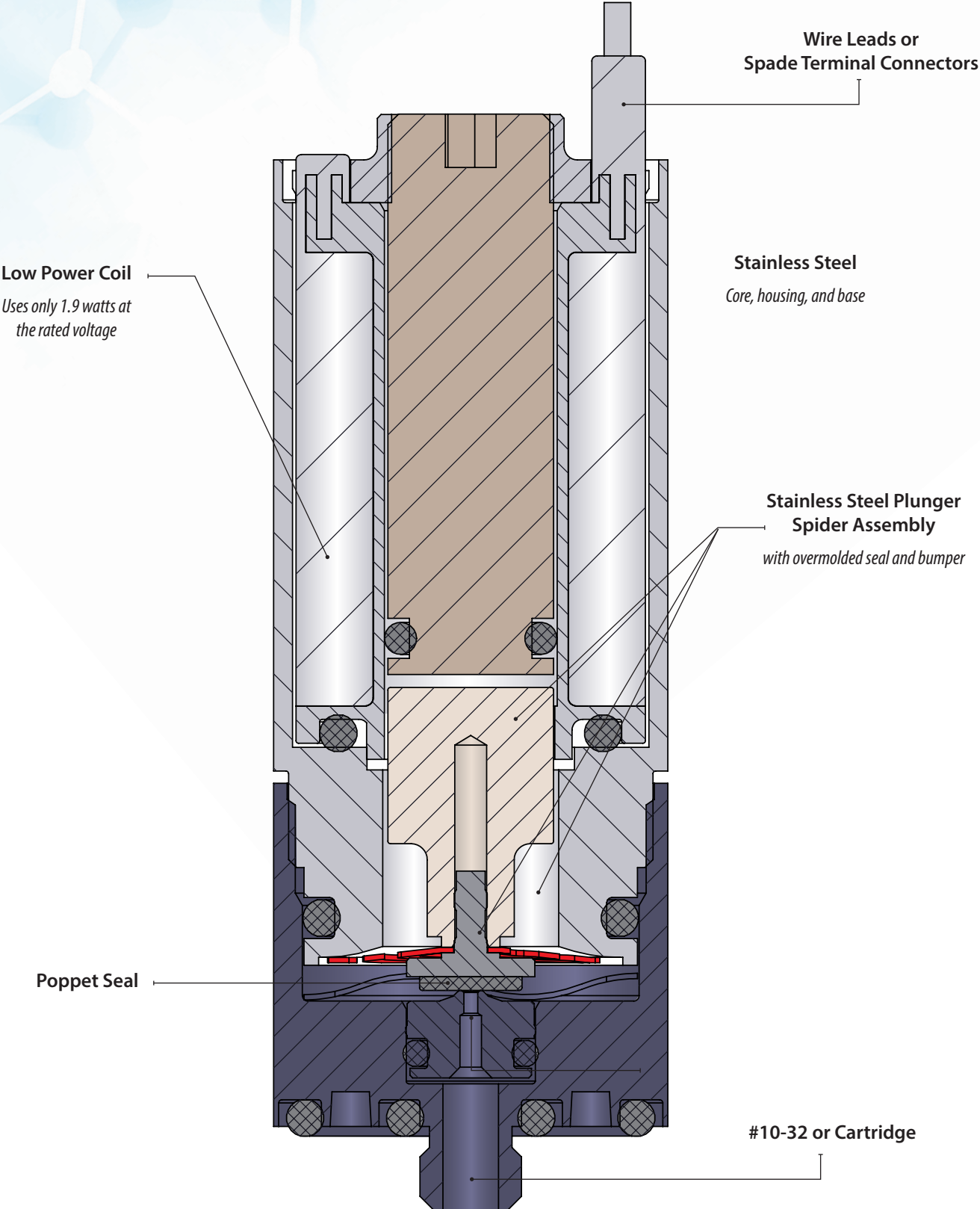

How to Select Your DVP Proportional Valve

Proportional flow is achieved by varying the current input to the valve. It is crucial to specify and use a calibrated valve that matches your application. To ensure you have a valve that will perform well for your specific requirements, be sure to use a valve set to your operating pressure.

The flow capabilities shown below in green are standard configurable options. The flow capabilities shown in blue are available as a special custom option. Contact Clippard for more details.

To select your valve, reference the flow chart and list your operating pressure in a 3-digit format (065 = 65 psig). Next, specify your desired maximum flow rate for your pressure (500 = 50.0 l/min). Accurately specify your nominal operating pressure and flow to ensure the best performance and resolution for your application.

For nominal operating pressures under 5 psig, use a 005 designator for pressure. For vacuum applications, use the positive pressure equivalent and reverse the ports.

When choosing your valve, there are many variables to consider. To select the best valve for your application, focus on:

- 1 Control Signal
- 2 Operating Pressure

Please Note: It is important to specify and use a calibrated valve that matches your application. Be sure to use a valve set to your operating pressure. Otherwise, the required power for opening the valve will be high and the resolution to set your flow proportional will be poor.

1 CONTROL SIGNAL

Voltage Range	Input Current Range	Coil Resistance	Max. Voltage Required
0 to 10 VDC @ 72°F	0 to 0.190A	52.6 ohms @ 72°F	13 VDC
0 to 20 VDC @ 72°F	0 to 0.095A	210.5 ohms @ 72°F	26 VDC

Note: Do not exceed input current range

2 OPERATING PRESSURE - Flow vs. Operating Pressure

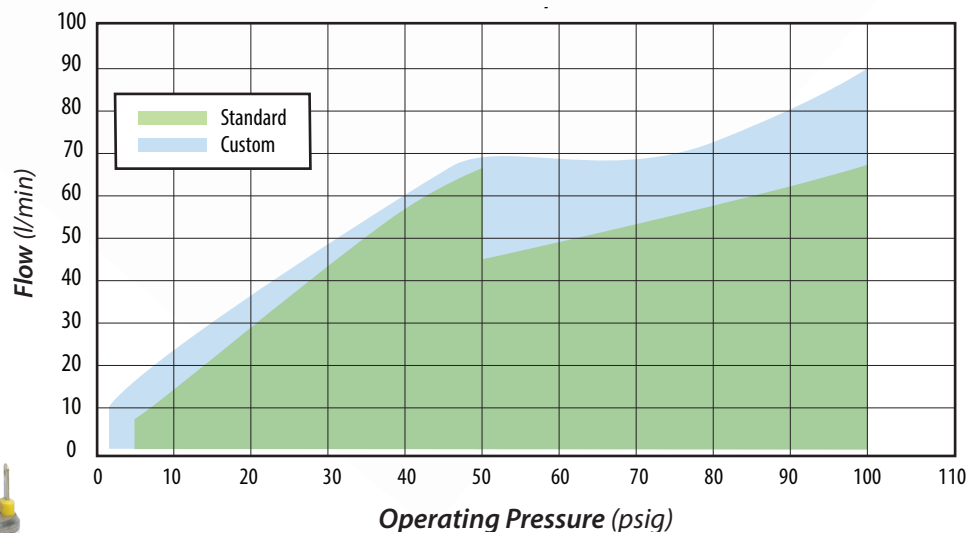

EVP / DVP DRIVER

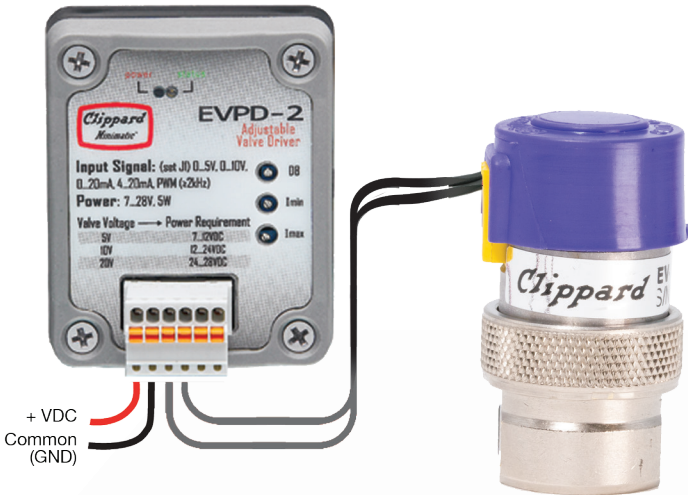

Adjustment	Min. drive current, max. drive current, command deadband
Command Set-Point Signal Type	Selectable: 0 to 5 VDC, 0 to 10 VDC, 0 to 20 mA, 4 to 20 mA, PWM @ ≥ 2 kHz duty cycle
Connection	Screw terminals or DIN connector
Input Impedance	200 k Ω
LED Indicators	Power, activity, status, and faults
Mount	Mounting holes or DIN rail
Operating Temp. Range	0 to 155°F (-18° to 68°C)
Output	0 to 400 mA (selectable range)
Power Requirement	7 to 28 VDC @5 watt
More Details	clippard.com/link/evpd-driver

The EVPD proportional valve driver fast-tracks valve control applications. This product is ideal for laboratories and OEM product development and can be customized to fit OEM applications including control parameters. The EVPD produces driver current for Clippard’s EVP or DVP series valves proportional to input control signals.

- Plug-and-play interface between Clippard’s EVP and DVP series valves and PLCs or other controls
- Linearized valve response right “out of the box”
- Three selectable valve output ranges
- Five signal inputs to choose from
- Easy integration with existing machine controls
- User-adjustable parameters
- Automatic temperature compensation to maintain constant current
- Two configuration options: stand-alone PCB or enclosed in housing
- Compact size

The tuning adjustments on the EVPD allow the user to adjust the command signal needed to start opening the valve, adjust the opening current to the valve, and limit the maximum current to the valve to restrict the valve maximum opening and prevent current beyond the valve solenoid’s rating. The settings are used by the valve management software in the microcontroller along with driver current feedback to calculate command instructions to the digital PWM controller.

The resulting change to valve performance is shown in the *Effect on Valve Flow* chart for a typical EVP valve (10 VDC coil, 0.06” orifice, 25 psig max).

Power Requirements

Power input requirements are specified as supply voltage ranges for each EVP or DVP valve. Supplying voltages outside of these ranges may result in valve malfunctioning. Power requirements are determined by the valve voltage specification.

EVP Valve Type	Input Voltage Range	EVPD Max. Output
0 to 5 VDC	7 to 12 VDC	400 mA
0 to 10 VDC	12 to 28 VDC	200 mA
0 to 20 VDC	14 to 28 VDC	100 mA

EVPD-2

EVPD-1

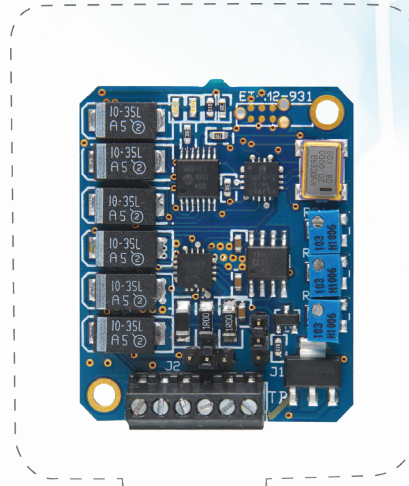
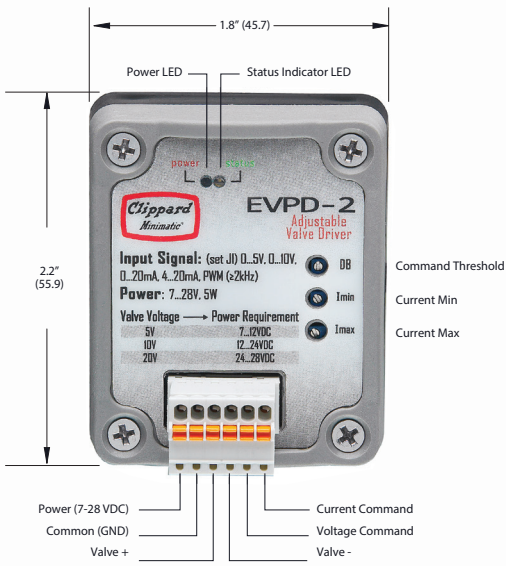

Dimensions shown are in inches (millimeters listed in parentheses).

Visit clippard.com for more detailed 2D and 3D drawings.



Effect on Valve Flow

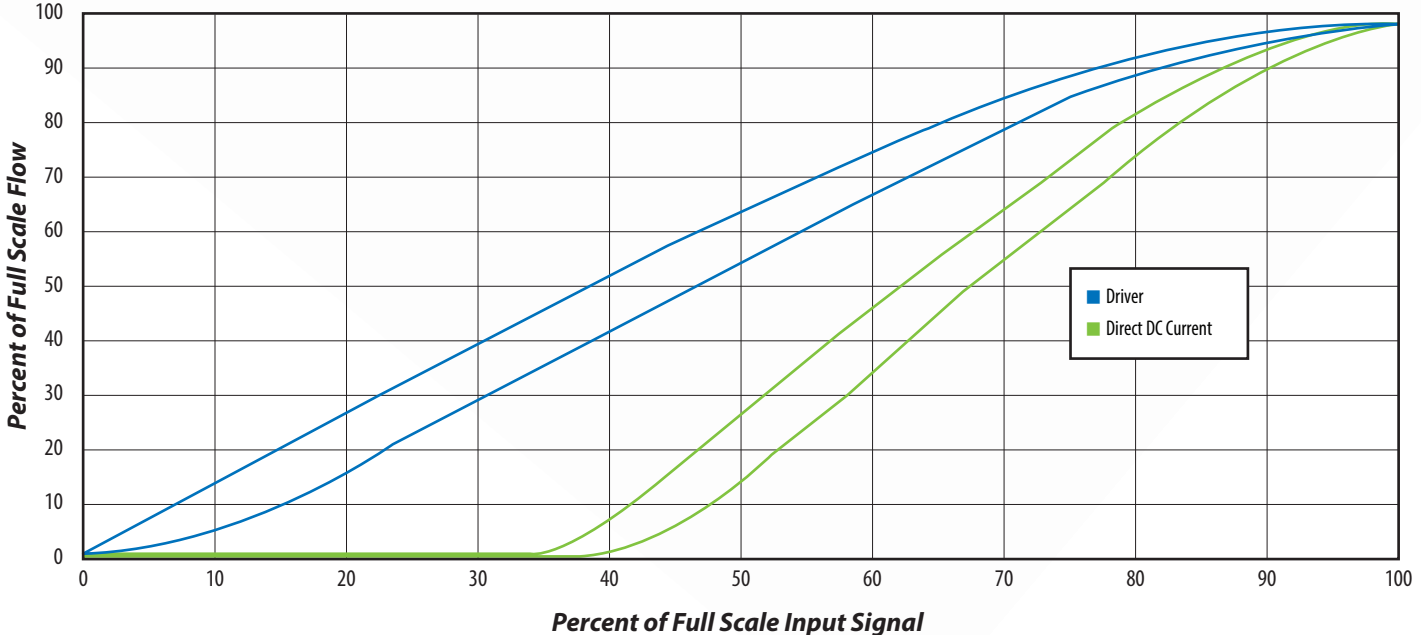

ORDERING INFORMATION

E V P D - □

- EVP Driver**
- 1 Driver Assembly in Enclosure
 - 2 Driver Board
 - 2DIN DIN Rail Mounting Clip

Example Part Number:
EVPD-1

For more info, scan the QR code or visit clippard.com/link/evpd-driver



SCPV NEEDLE VALVES



Utilizing the industry's most robust and powerful linear actuator, the SCPV series high flow stepper-controlled proportional valves outperform the competition in performance and durability. These valves are ideal in critical applications such as gas delivery, medical, analytical, and industrial automation requiring high resolution, high flow, and low hysteresis. In addition, the unique design allows for custom flow profiles when required.

Positioning a 3.5° needle through a 0.152" (3.9 mm) orifice in 0.001" (0.03 mm) step increments provides for very linear and repeatable flow control within your application process. Standard models, inline, cartridge, and manifold mounts are ready to go for control of air and other inert gases.

Connection	Connector / wiring harness
Driver	Bipolar chopper drive required
Flow Range	Up to 280 l/min
Flow Resolution	0.7 l/min per step
Linearity	<2.5% of full scale
Material, Wetted	Stainless steel, aluminum, brass, acetal, and FKM
Max. Hysteresis	<2%
Max. psig	100 psig
Medium	Air or compatible gases
Mount	In-line, manifold, or cartridge
Needle	3.5°
Number of Ports	2
Operating Pressure	Vac. to 100 psig (7 bar)
Operating Temp. Range	32 to 184°F (0 to 84°C)
Port, Inlet	1/8" NPT, manifold, or cartridge
Port, Outlet	1/8" NPT, manifold, or cartridge
Position Resolution	0.001" (0.03 mm) per step
Power Requirement	5 VDC supply to motor
Repeatability	<0.5% of full scale
Response Time	0.95 secs fully-open to fully-closed
Wattage	3.85 watts nominal (<i>only during adjustment—zero power consumption to maintain position</i>)
More Details	clippard.com/link/scpv-series

Flow Rate (SCPV-1-3 @ 100 psig)

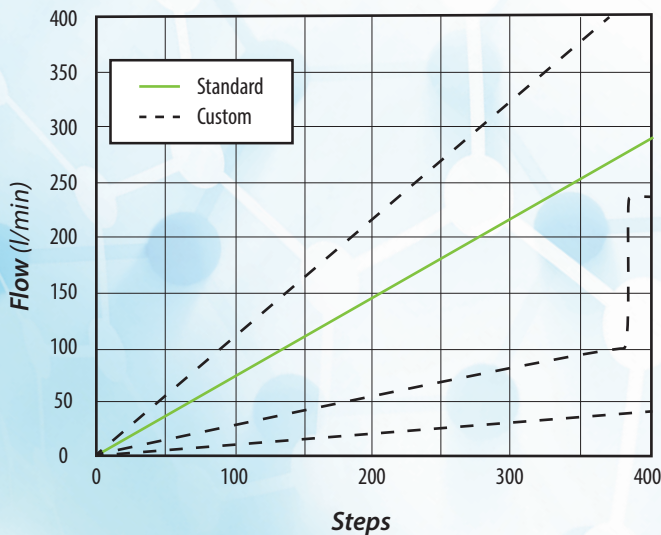

CUSTOMIZABLE FOR YOUR APPLICATION

The SCPV is highly modifiable for OEM applications, including:

- Flow profiles up to 5,800 l/min
- High flow at low pressure
- Materials such as PEEK or stainless steel
- Special seal materials such as FFKM and others
- Applications for control of water
- Applications that provide zero leak shutoff
- Changing the motor to accommodate an encoder
- Providing specific testing procedures

Contact Clippard to discuss what changes can be made to best fit your application requirements.

Inline Mount

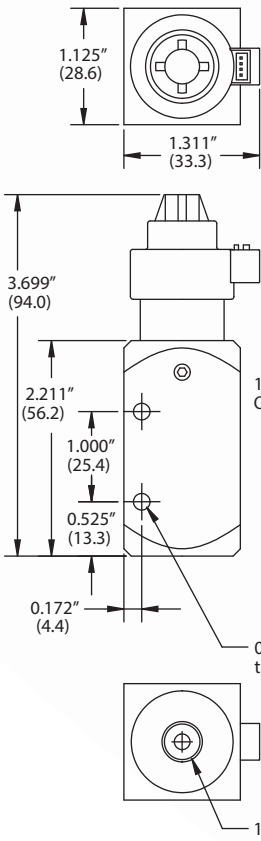

Dimensions shown are in inches
(millimeters listed in parentheses).

Visit clippard.com for more detailed
2D and 3D drawings.

Cartridge Mount

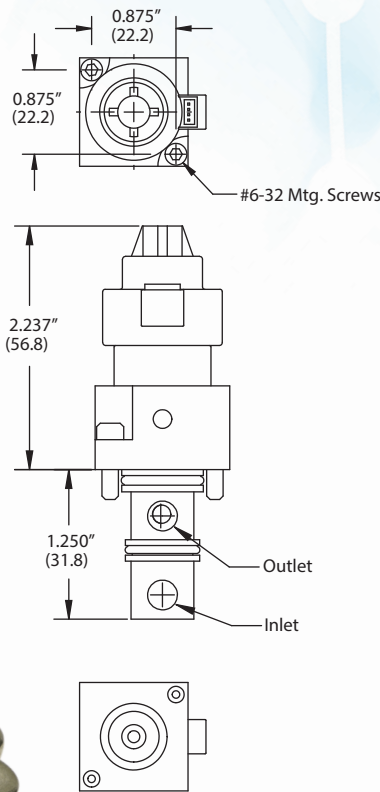

Manifold Mount

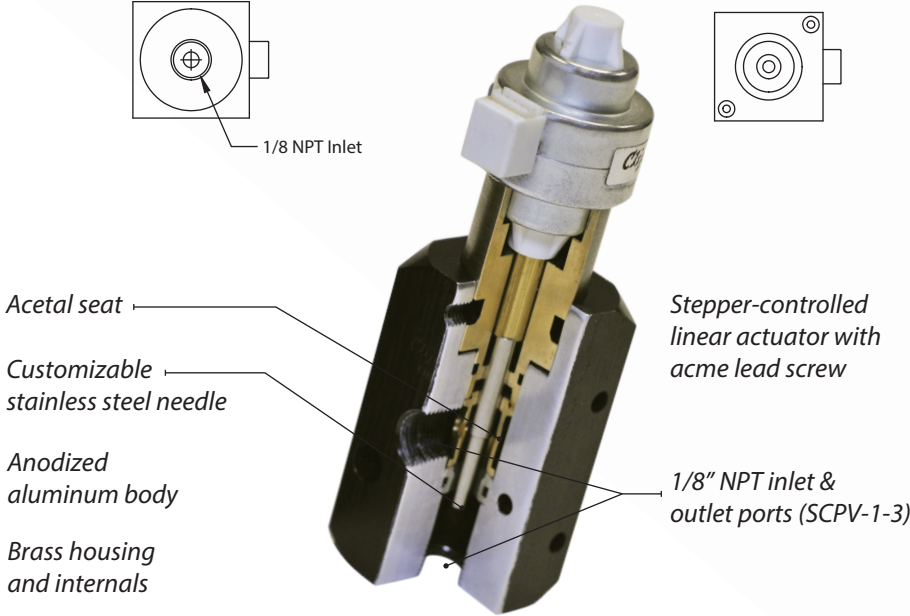
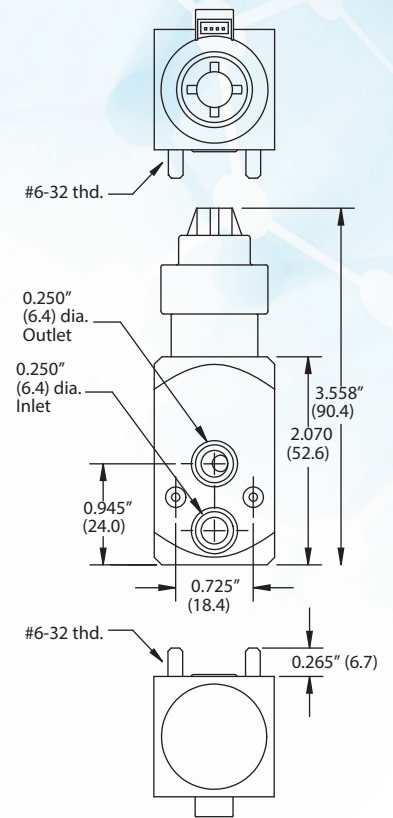

Stepper-controlled
linear actuator with
acme lead screw

- <2% hysteresis
- Excellent linearity, <2.5% of full-scale
- 2 ms reaction time
- Millions of cycles
- Holds position for power savings or at a loss of power

ORDERING INFORMATION

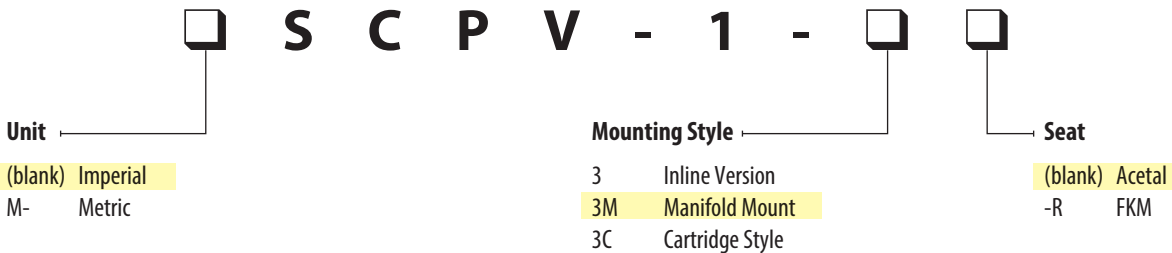

Example Part Number:
SCPV-1-3M

For more info, scan the
QR code or visit
clippard.com/link/scpv-series



ECLIPSE PROPORTIONAL ISOLATION VALVE



The Eclipse is a proportional isolation valve like no other. Utilizing patented slide technology, it achieves exceptional proportional flow resolution that far exceeds the competition. Designed for precision, its flow path is fully flushable and composed entirely of inert ceramic, ensuring compatibility with a wide range of media. In addition, the Eclipse features a unique soft start capability that gradually introduces media at a controlled ramp rate to prevent damage or turbulence.

Utilizing a robust and powerful miniature linear actuator, the Eclipse is stepper-controlled, micro-stepping capable, encoder-ready, and its unique design allows for custom flow profiles.

For applications that demand exceptional liquid and gas control, Clippard's Eclipse offers outstanding precision and unrivaled proportional flow resolution.

- **Unrivaled resolution**
- **Inert flow path** (*all wetted areas ceramic*)
- **Soft start prevents damage or turbulence**
- **Zero dead volume** (*fully flushable, <0.0009 in³*)
- **Excellent linearity** (*<4% of full-scale*)
- **Fast response** (*<2 ms reaction time*)
- **Cycle life of typically >1 million cycles**
- **Repeatability <5% of full travel**
- **Bi-directional**

Current	0.49A per phase
Cycle Life	Typically >1 million
Driver	Bipolar chopper drive required
Flow Range	Air: 0 to 7 l/min Water: 0 to 190 ml/min -0 / +10% @ 30 psig (2 bar)
Flow Resolution	Air: 0.000487 l/min (487.5 µl) @ 30 psig (2 bar) Water: 0.0002 l/min (200 µl) @ 30 psig (2 bar)
Linearity	<4% of full-scale
Material, Body	Ceramic
Material, Seals	FKM standard, EPDM and others available
Material, Wetted	Ceramic (others depending on porting option)
Max. Flow	Air: 0 to 7 l/min -0 /+10% Water: 0 to 190 ml/min -0 /+10% @ 30 psig (2 bar)
Max. psig	30 psig (2 bar)
Medium	Liquids and gases
Mount	Manifold or flat bottom (ZDVF)
Number of Ports	2
Operating Pressure	Vac. to 30 psig (2 bar)
Operating Temp. Range	32 to 180°F (0 to 82°C)
Port, Exhaust	None
Port, Inlet	#10-32, Manifold or ZDVF (<i>zero dead volume fitting</i>)
Port, Outlet	#10-32, Manifold or ZDVF (<i>zero dead volume fitting</i>)
Position Resolution	0.00006" (0.0015 mm)
Power Requirement	20 VDC supply to motor @ 30 psig (2 bar)
Proof Pressure	50 psig (3.4 bar)
Response Time	<2 ms
Wattage	2.5 watts nominal (<i>only during adjustment, zero power consumption to maintain position</i>)
More Details	clippard.com/link/eclipse-valve

**This product is highly modifiable for OEM applications, including alternate body materials, flow profiles, and more. Call 877-245-6247 to discuss your needs.*

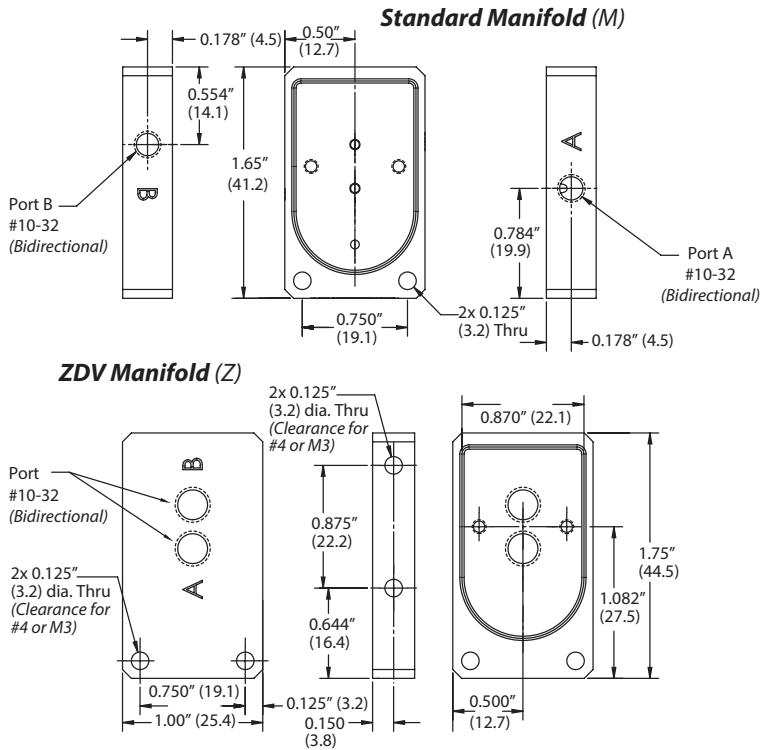
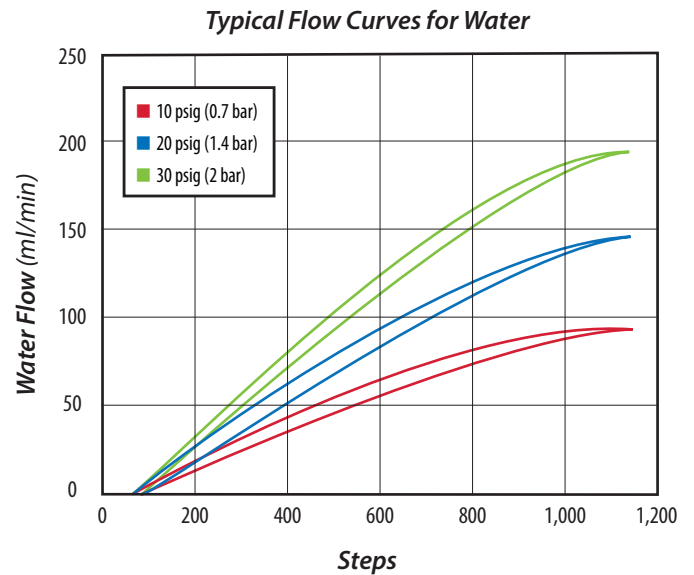
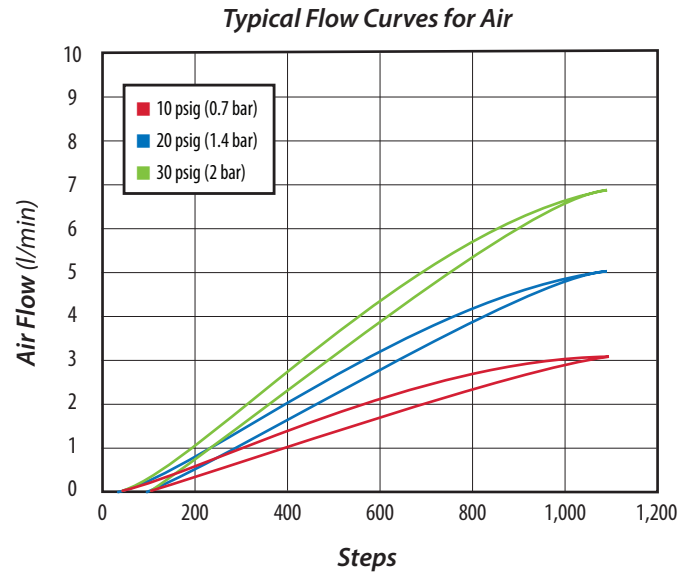
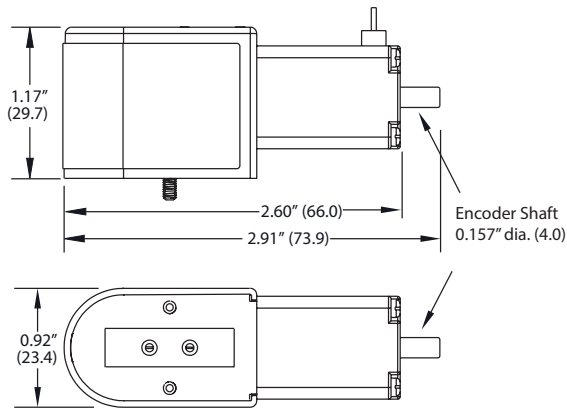

Dimensions shown are in inches (millimeters listed in parentheses).
 Visit clippard.com for more detailed 2D and 3D drawings.

ORDERING INFORMATION

E I V U

Porting

M Manifold
Z Zero Dead Volume Manifold

Seals

(blank) ZDVF porting
-V FKM

Encoder Shaft

-ENS Encoder shaft (standard)
 (blank) No encoder shaft

Accessories

- EUM-01 Single-Station Manifold, #10-32
- M-EUM-01 Single-Station Manifold, M5x0.8
- SCPVD-1 Bipolar Chopper Driver
- ZDVF-18 Headless 1/4-28 Flatbottom Fitting, 1/8" (3.2 mm) OD (IDEX p/n XP-348)

Also Recommended: Miniature optical encoder from US Digital for 4 mm bore with metric screws (p/n E4T)

Example Part Number:
EIVU-M-V-ENS

For more info, scan the QR code or visit

clippard.com/link/eclipse-valve



SCPV DRIVER

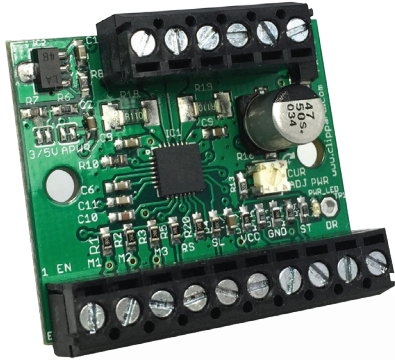

Current / Phase	385 mA
Inductance / Phase	8.08 mH
Insulation Resistance	20M ohms
Motor Voltage	5 VDC
Resistance / Phase	13 ohms
Temperature Rise	135°F (57°C)
Wattage	3.85 watts
More Details	clippard.com/link/scpvd-driver

**This product is highly modifiable for OEM applications—including alternate body materials, flow profiles, and more. Call 877-245-6247 to discuss your needs.*

The SCPVD is a bi-polar stepper motor driver board which can be used for stepper motors up to a max 2A/phase. It is based on the Allegro A4988 motor driver. The driver requires a motor drive voltage of 7 to 35 volts. An external controller is required to deliver step and direction signals to the driver board. The SCPVD is capable of microstepping and defaults to a 16th step micro-stepping mode. The step mode as well as several other options such as sleep, enable, and reset can be toggled on and off.

Max. Step Pulse Frequency

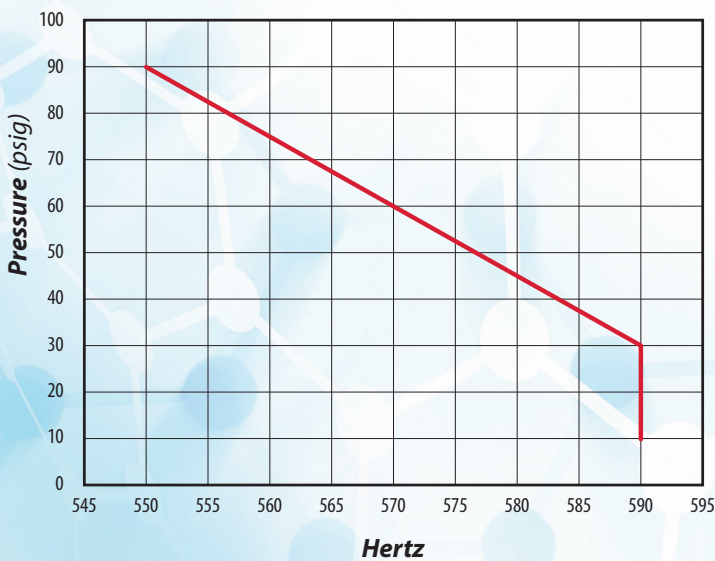

For Use with Clippard's

**SCPV Series
Stepper-Controlled
Proportional Valve**

and/or

**Eclipse Proportional
Isolation Valve**



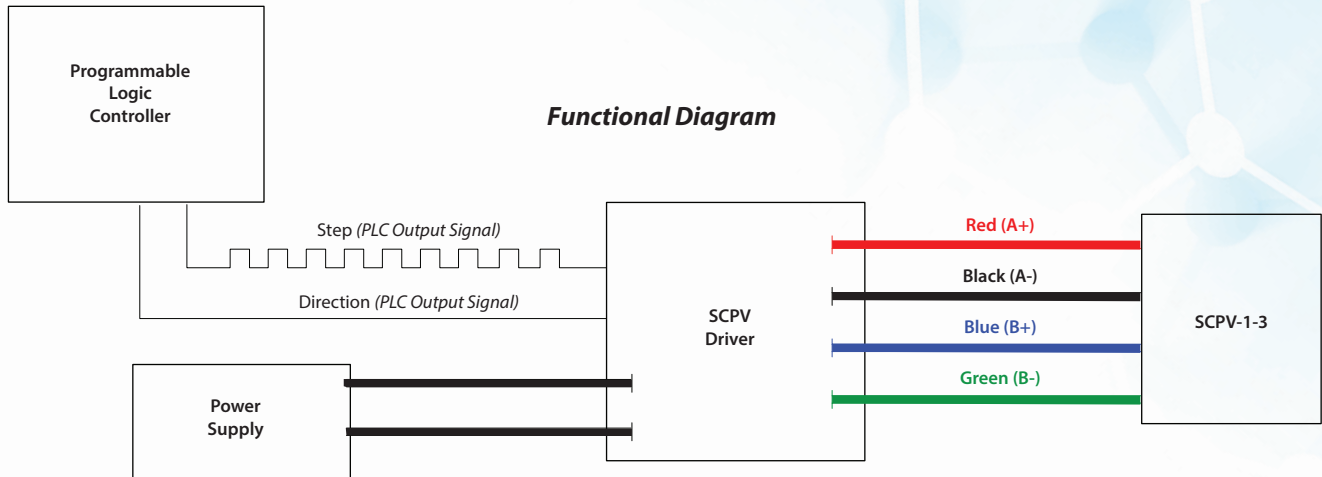

Applications

- Analytical instruments
- Blood pressure monitoring
- Precise pressure control
- Patient simulators
- Gas controllers
- Mass flow control
- Gas chromatography
- Respirators / ventilators

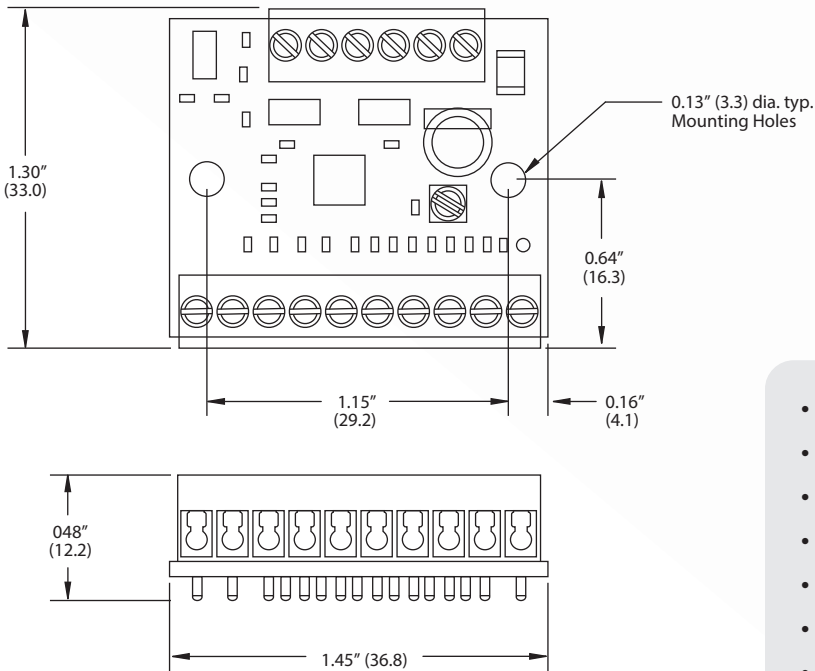

Dimensions shown are in inches (millimeters listed in parentheses).

- +7 to +35 VDC supply voltage
- Max. 2A / phase
- 1/16, 1/8, 1/4, 1/2, and full step modes
- 5V or 3.3V logic inputs (jumper selectable)
- LED power supply indicator light
- Crossover current protection
- Thermal shutdown circuitry

ORDERING INFORMATION

S C P V D - 1

Example Part Number:
SCPVD-1

For more info, scan the
QR code or visit
clippard.com/link/scpvd-driver



BPV BALANCED POPPET SERIES



Clippard's new pressure compensated valve, the BPV, is another addition to an impressive list of quality flow control products! The new BPV series provides all the qualities you've come to rely on with the EVP/DVP proportional valves, but with design features that address critical low pressure/high flow applications.

- Small package with significant flow
- All ports down design
- Wetted parts ideal for oxygen and inert gases
- Smooth liftoff
- Low hysteresis
- Low leak design
- Ideal for low pressure/high flow applications
- Can be calibrated to meet specific applications

Connection	Flying leads
Cycle Life	>100 million
Flow	120 l/min @ 30 psig (2 bar)
Function	2-way normally-closed proportional
Hysteresis	10% of full scale typical, 15% max.
Material, Seals	FKM
Material, Wetted	303 stainless steel, PPS (manifold mount), 430FR stainless steel, brass
Medium	Air, oxygen, or neutral gas
Mount	Cartridge or manifold
Operating Pressure	0-45 psig (3 bar)
Operating Temp. Range	50 to 122°F (10 to 50°C)
Response Time	10 ms
Voltage	5, 12, or 24 VDC
Wattage	2.5 watts typical
More Details	clippard.com/link/bpv

PRELIMINARY

Note: This product is still in development.
Specifications are subject to change.

Typical Flow @ 45 psig (2 bar)

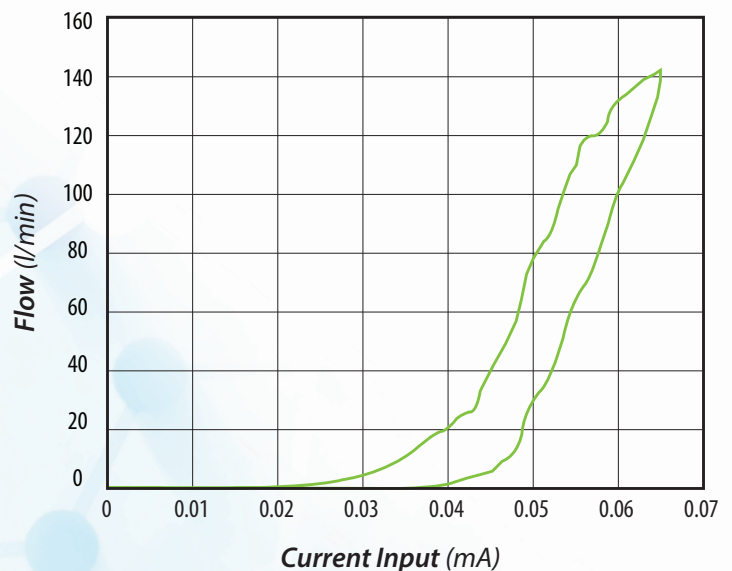

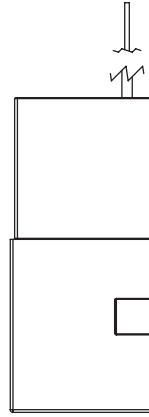
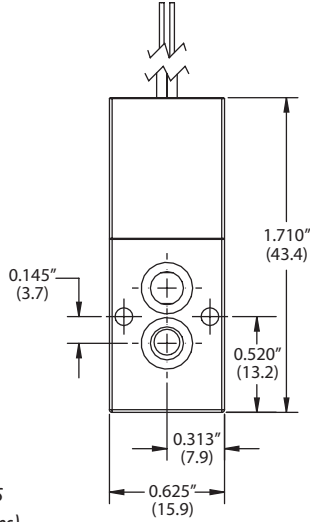
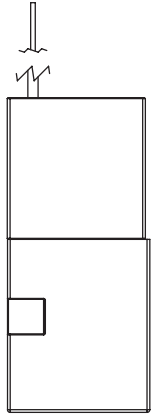

Hole Placement For Manifold

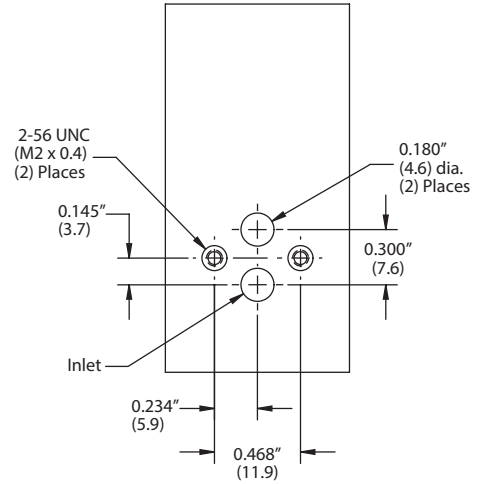

Dimensions shown are in inches
(millimeters listed in parentheses).

Visit clippard.com for more detailed
2D and 3D drawings as they
become available.

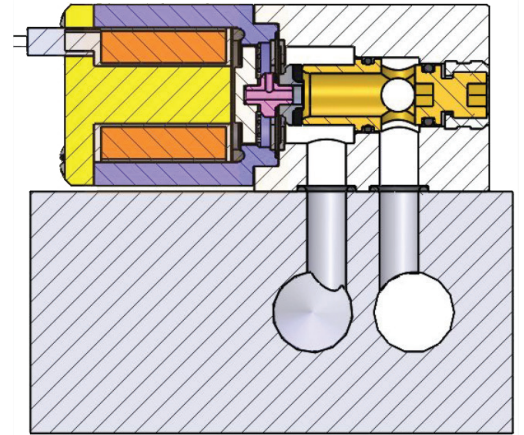
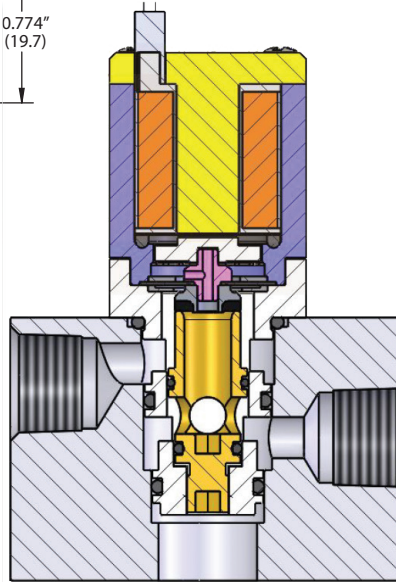
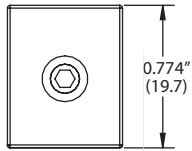

Applications

- Medical devices
- Analytical instruments
- Biotechnology
- Industrial process controls
- Food and beverage equipment

ORDERING INFORMATION

Not Yet Available to Order—**Coming Soon!**

Contact Clippard or your local Clippard distributor to discuss participating in the early Beta release

For more info, scan the
QR code or visit
clippard.com/link/bpv



CPV8 MICRO 8 MM SERIES



These direct actuating proportional valves offer an extremely fast response time for precise, proportional dosing of minute volumes. They are extremely quiet, emit very low vibration, and consume very little power, making them ideal for a wide range of medical and diagnostic applications.

Standard products offered will fit the needs of most applications, however this series can be fully customized according to the user's unique requirements. Consult Clippard with your specific application.

- Ideal for compact assemblies
- Eliminates downstream pulsations
- Smooth proportional delivery
- Low current power / low to no noise
- Exceptional variability of flow vs. command current
- Tiny package with a robust design
- Highly customizable performance

Current Range	0 to 70 mA
Duty Cycle	100% @ I < 55 mA
Flow Coefficient Kv	0.012" Orifice: Up to 0.003 m ³ /h 0.020" Orifice: Up to 0.005 m ³ /h
Function	2-way normally-closed proportional
Leak Rate	< 1 ml/min
Material, Body	Stainless steel
Material, Seals	FKM, FFKM
Max. Flow	7.5 l/min
Medium	Air, inert gases
Mount	Cartridge
Operating Pressure	0.012" Orifice: 0 to 116 psig (10 bar) 0.020" Orifice: 0 to 87 psig (6 bar)
Operating Temp. Range	40 to 120°F (5 to 50°C)
Orifice	0.012" (0.3 mm), 0.020" (0.5 mm)
Thermal Resistance	~70 K/W (without flow)
Voltage	32 V
Wattage	1.5 watts max.
More Details	clippard.com/link/pv8

PRELIMINARY

Note: This product is still in development.

Specifications are subject to change.

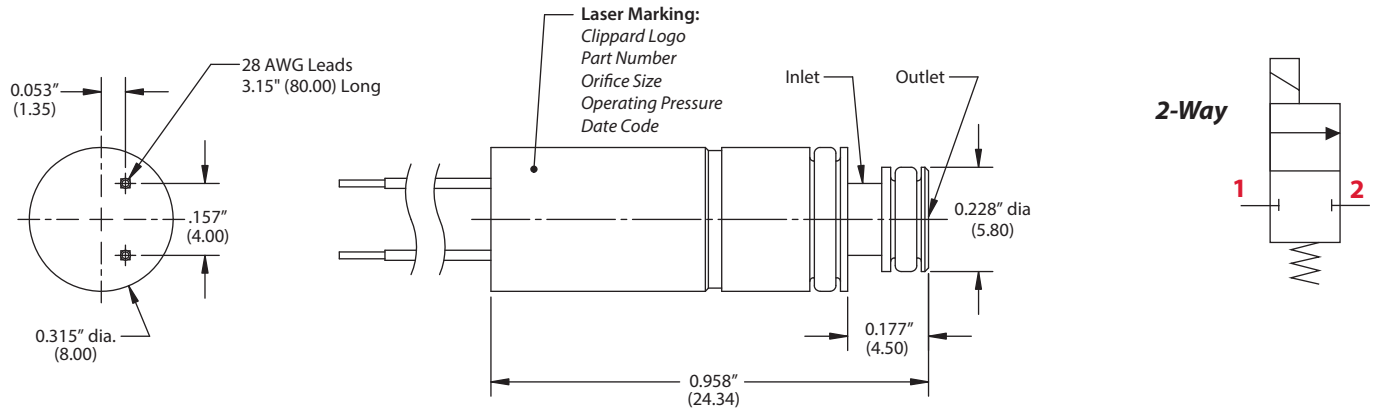

Dimensions shown are in inches (millimeters listed in parentheses).
Visit clippard.com for more detailed 2D and 3D drawings as they become available.

Typical Performance for 0.012" Orifice (Air)

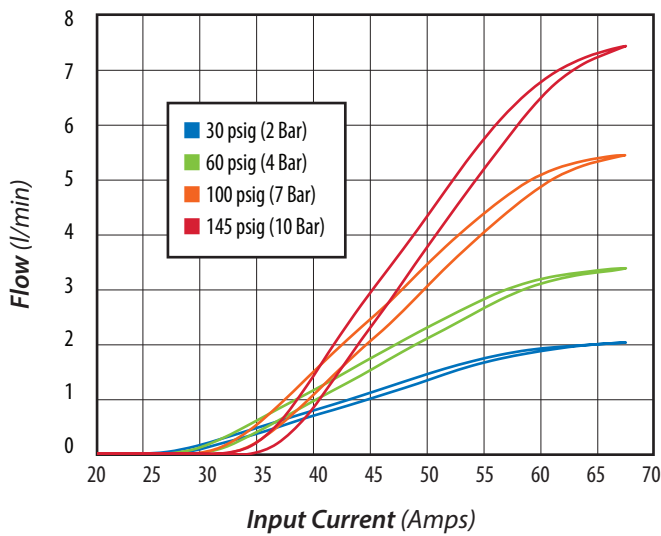

Typical Performance for 0.020" Orifice (Air)

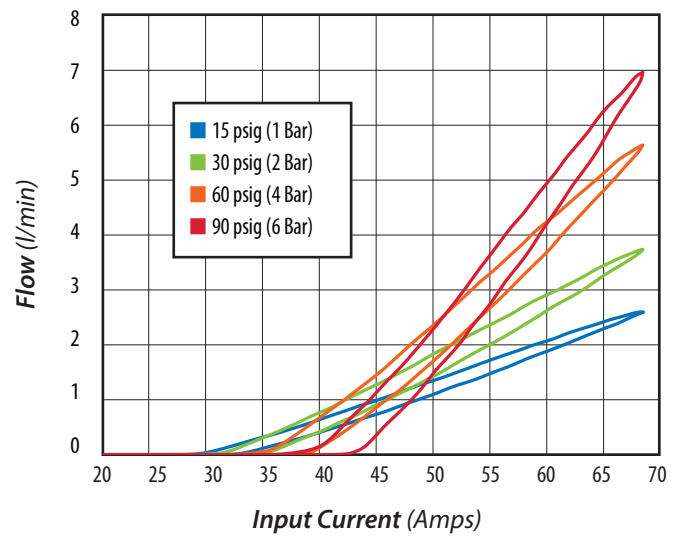

ORDERING INFORMATION

Not Yet Available to Order—*Coming Soon!*

For more info, scan the
QR code or visit
clippard.com/link/pv8



Clippard products are distributed through our worldwide network of sales and engineering specialists. All of our representatives are stocking distributors and keep a variety of Clippard products on hand to fill your immediate needs. Each of our distributors are backed by our own large inventory to ensure quick delivery.

To locate your nearest distributor, call 877-245-6247 or visit clippard.com/distributors



ELECTRONIC VALVES

PROPORTIONAL VALVES

ISOLATION VALVES

ELECTRONIC CONTROLS

CUSTOM SOLUTIONS

PRESSURE REGULATORS

CONTROL VALVES

DIRECTIONAL CONTROL VALVES

AIR PILOT VALVES

AIR PREPARATION EQUIPMENT

FITTINGS, HOSE, & TUBING

Clippard

United States

1-877-245-6247

Europe

+32 10-45-21-34

China

+86 137-9527-9010

DISTRIBUTED BY:



*Scan QR code or visit
clippard.com/link/request-literature
to request additional literature.*